

RECENT EVOLUTIONARY HISTORY OF THE FOX SPARROWS (GENUS: *PASSERELLA*)

ROBERT M. ZINK¹ AND JASON D. WECKSTEIN²

Bell Museum of Natural History, 100 Ecology Building, University of Minnesota, St. Paul, Minnesota 55108, USA

ABSTRACT.—On the basis of plumage coloration and mitochondrial DNA variation, four main groups are recognized within the Fox Sparrow (*Passerella iliaca*): the red group (*iliaca*, RE), sooty group (*unalaschensis*, SO), thick-billed (*megarhyncha*, TB), and slate-colored (*schistacea*, SC). To establish phylogenetic relationships among those four groups, we analyzed 2119 base pairs of sequence from four mitochondrial regions: ND2, ND3, cytochrome *b*, and control region. The control region is less variable than the coding genes surveyed. Both maximum parsimony and maximum likelihood resolved the same ingroup relationships (RE(SC(TB,SO))). However, placement of the root could not be established, even with four outgroups. Lack of resolution of the root is due to the nearest living relative of the Fox Sparrow being over 11% divergent. Despite lacking a clear root, the data suggest that the two taxa connected by a hybrid zone (TB, SC) are not sister species, which has implications for species limits because under the biological species concept they should be lumped. We recommend that all four main groups be recognized as species. Received 17 January 2001, accepted 14 December 2002.

RESUMEN.—Con base en la coloración del plumaje y variación en el ADN mitocondrial, se reconocen cuatro grupos dentro de *Passerella iliaca*: el grupo rojo (*iliaca*, RO), el grupo fuliginoso (*unalaschensis*, FU), el grupo de pico grueso (*megarhyncha*, PG) y el grupo de color pizarra (*schistacea*, CP). Para establecer las relaciones filogenéticas entre estos cuatro grupos, analizamos 2119 pares de bases de cuatro regiones mitocondriales: ND2, ND3, citocromo *b* y la región control. La región control es menos variable que los genes codificantes estudiados. Análisis de parsimonia y máxima verosimilitud resolvieron las mismas relaciones en el grupo (RO(CP(PG,FU))), pero no fue posible establecer la raíz del árbol, aún usando cuatro grupos externos. La poca resolución de la raíz se debe a que la divergencia entre *P. iliaca* y el grupo viviente más cercano es superior al 11%. A pesar de la incertidumbre en cuanto a la raíz, los datos sugieren claramente que los dos taxa que están conectados por una zona de hibridación (PG y CP) no son hermanos, lo que tiene implicaciones para establecer los límites específicos, pues bajo el concepto biológico de especie deberían ser considerados coespecíficos. Recomendamos que los cuatro grupos sean reconocidos como especies diferentes.

THE FOX SPARROW (*Passerella iliaca*) is the third most polytypic biological species of North American birds. The American Ornithologists' Union (1957) recognized 18 subspecies of *P. iliaca*. However, detailed investigations of geographic variation in plumage, morphology, osteology, mitochondrial DNA (mtDNA) restriction fragment length polymorphisms (RFLP), and mitochondrial cytochrome-*b* sequences (Swarth 1920; Linsdale 1928; Zink 1986, 1994; Zink and Blackwell 1996) detect 3 or 4 groups

of *Passerella* instead of the 18 units implied by the subspecific nomenclature. Four groups can be characterized by plumage, bill morphology, and breeding distribution: The reddish plumaged *iliaca* group (Red Fox Sparrow; RE) breeds from Newfoundland to northern Alaska; the slate-colored *shistacea* group (Slate-colored Fox Sparrow; SC) is distributed throughout high elevation riparian zones in the Great Basin and the Rocky Mountains; the thick-billed *megarhyncha* group (Thick-billed Fox Sparrow; TB) breeds in high elevation chaparral in southern Oregon and California (west slope of the Sierra Nevada); and, the sooty plumaged *unalaschensis* group (Sooty Fox Sparrow; SO) is coastally distributed from the Aleutian Islands to Vancouver Island.

Although taxonomic limits of the four groups are established (Zink 1986, 1994; Zink and Blackwell 1996), their phylogenetic rela-

¹Present address: 1987 Upper Buford Circle, 100 Ecology Building, University of Minnesota, St. Paul, Minnesota 55108, USA. E-mail: rzink@biosci.umn.edu

²Present address: Museum of Natural Science, 119 Foster Hall, Louisiana State University, Baton Rouge, Louisiana 70803, USA.

tionships are unresolved. Analysis of mtDNA RFLPs (Zink 1994) suggested the following topology (RE (TB (SO, SC))). However, the node uniting Sooty and Slate-colored taxa was supported in only 77 of 100 bootstrap replicates, and furthermore, the tree was unrooted. Zink and Blackwell (1996) analyzed 433 base pairs (bp) of cytochrome *b* (*cyt b*) and were unable to resolve the relationships among the four *Passerella* groups using maximum parsimony. However, a neighbor-joining tree built from their *cyt-b* data matched the topology of Zink's (1994) RFLP tree. To resolve the phylogenetic relationships of the four groups of *Passerella*, we analyzed longer sequences from the mtDNA genome and added multiple outgroups.

METHODS

We included multiple individuals of the four Fox Sparrow groups (Zink 1994) including Red Fox Sparrow (Newfoundland [$n = 1$], Alaska [$n = 1$]), Slate-colored Fox Sparrow (Colorado [$n = 2$], Nevada [$n = 1$]), Thick-billed Fox Sparrow (California [$n = 3$], Oregon [$n = 1$]), Sooty Fox Sparrow (Aleutian Islands [$n = 1$], Alaska [$n = 1$], Queen Charlotte Islands [$n = 1$], Vancouver Island [$n = 1$]), and one individual of each of four outgroup taxa, Green-tailed Towhee (*Pipilo chlorurus*), Dark-eyed Junco (*Junco hyemalis*), White-crowned Sparrow (*Zonotrichia leucophrys*), and American Tree Sparrow (*Spizella arborea*). These outgroups represent the closest extant relatives to *Passerella* based on extensive sequencing (J. Klicka pers. comm.). We also explored the influence of outgroup composition by excluding the Green-tailed Towhee, owing to its relatively greater divergence.

Ultrapurified mtDNA (Lansman et al. 1981) also used by Zink and Blackwell (1996) was used as template to sequence 1,686 bp of three mitochondrial genes (Control Region I [CR I]: 308 bp, ND2: 1030 bp, ND3: 348 bp). We also added *cyt-b* sequences (433 bp) originally published in Zink and Blackwell (1996) and Dodge et al. (1995) (Genbank accession numbers U40162–U40186 and U26190). Collecting localities, collection dates, and specimen voucher numbers for newly sequenced individuals are associated with Genbank sequence accession numbers (AY138903–138953). We used the protocol of Kocher et al. (1989) with standard thermal cycling regimes for polymerase chain reaction (PCR) (authors can provide cycling regimes used for specific primers). Polymerase chain reaction products were examined on a 1% agarose gel (Seakem LE, FMC) to verify the presence of the desired products. For all regions sequenced, we performed PCR amplifications with the same external primers used for sequencing. We manually sequenced double-stranded PCR products from CR I using the

Sequenase PCR Product Sequencing Kit (United States Biochemical, Cleveland, Ohio) and primers LGL2 and HCR4 (Tarr 1995). For CR I, excess dNTP and primers were removed from PCR product by enzymatic treatment with Exonuclease I and Shrimp Alkaline Phosphatase (United States Biochemical). Sequenced product was run through 6% polyacrylamide gels and visualized by autoradiography (^{35}S). We used external primers L5215 (Hackett 1996) and H6313 (Johnson and Sorenson 1998) and internal primers L5758 (Johnson and Sorenson 1998) and H5776b (modified from H5776 of Klicka et al. [2000], 5'-TGGGAGATRGARGARAAAGC-3') to sequence ND2. To sequence ND3, we used primers L10702 (5'-CTCTACACAACCATCTACTGATGAGG-3') and H11285 (5'-GATAGTATTATGCTTTCTAGGCA-3' (J. Groth pers. comm.)) We sequenced ND2 and ND3 on an ABI377 automated DNA sequencer. The PCR products were purified using a QIAquick PCR Purification Kit (Qiagen, Valencia, California) and then cycle sequenced, using ~75 ng of double stranded PCR product, fluorescent dye terminators, and AmpliTaq FS (Applied Biosystems, Foster City, California). Unincorporated dyes were removed from sequencing reaction products using Centri-sep columns (Princeton Separations, Adelphia, New Jersey) filled with Sephadex G-50. Automated sequences were examined and reconciled from both forward and reverse strands using SEQUENCHER 3.1.1 (GeneCodes, Ann Arbor, Michigan). Sequences were aligned visually owing to the absence of indels in coding genes and their scarcity in CR.

We used the computer program MEGA (Kumar et al. 1993) to calculate transition and transversion divergences, transition to transversion ratios, Kimura (1980) two-parameter distances, and to translate protein-coding sequences. We constructed saturation plots of Kimura (1980) two-parameter sequence divergence versus percentage transition and percentage transversion divergences to check sequences for evidence of saturation. We tested for incongruence in phylogenetic signal between the four gene regions using the partition homogeneity test (Farris et al. 1994, 1995) implemented in PAUP* (Swofford 2000). All phylogenetic analyses were conducted using the computer program PAUP* (Swofford 2000). We performed maximum-parsimony analysis using the Branch and Bound search option, with all characters unordered and weighted equally. We also performed 1,000 bootstrap replications (Felsenstein 1985). To construct a maximum-likelihood tree, we obtained parameters from MODELTEST (Posada and Crandall 1998) and implemented a heuristic search in PAUP* with 100 random starting points. One hundred bootstrap replications were then performed with those parameters. To test alternative topologies we used the Shimodaira-Hasegawa test (Shimodaira and Hasegawa 1999).

RESULTS

Of 2119 bp sequenced, 85 sites were variable and 52 sites were parsimony informative (outgroups excluded). A comparison of the percentages of variable and phylogenetically informative characters between regions indicated that CR I is roughly half as variable as the coding regions sequenced (Table 1). The transition–transversion ratio calculated for all four regions sequenced is 5.9. Saturation plots (not shown) for all four genes sequenced show linear relationships between Kimura (1980) two-parameter sequence divergence and both percentage transition divergence and percentage transversion divergence. Average Kimura (1980) two-parameter sequence divergence among the four groups of *Passerella* is 0.013. The groups are essentially all the same distance apart, ranging from 0.012 between red and slate-colored to 0.017 between red and sooty. Sequence divergence within groups averages 0.005. The partition homogeneity test (Farris et al. 1994, 1995) was not significant ($P = 0.19$).

Both maximum parsimony and likelihood analyses grouped haplotypes from the same groups together with over 95% bootstrap support; hence, below we refer to relationships of groups rather than individual haplotypes. Including all outgroups, maximum parsimony and maximum likelihood resolved the same topology with RE basal (Fig. 1A). Excluding the Green-tailed Towhee, maximum parsimony analysis yielded the same tree whereas maximum likelihood analysis (Fig. 1A) yielded the following topology (TB(SO(SC,RE))). Those two topologies differ only in placement of the root (Fig. 1B), thereby suggesting that relationships among the four fox sparrow taxa are resolved. The Shimodaira-Hasegawa test failed to reject ($P = 0.14$) a topology in which SC and TB were sisters. Bootstrap analysis yielded only one relevant node, that containing RE, SO, and SC (61%).

TABLE 1. Percentage of variable and phylogenetically informative sites in each region sequenced.

	CR I	ND2	ND3	Cyt <i>b</i>
Variable (%)	2.0	4.7	3.7	4.0
Parsimony (%)				
Informative	1.6	2.5	2.9	2.5

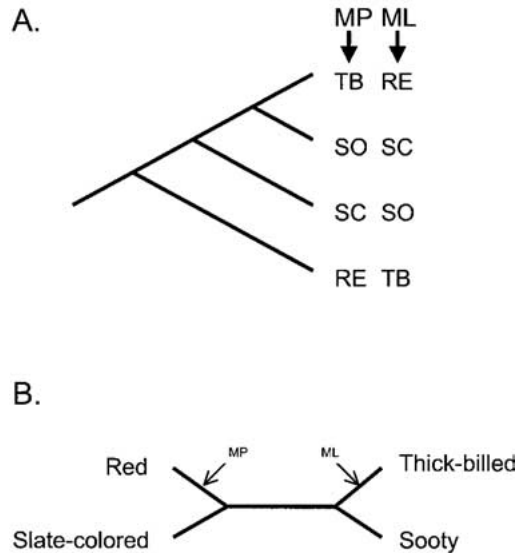

FIG. 1. (A) Rooted trees based on maximum parsimony (MP) or maximum likelihood (ML) with Green-tailed Towhee excluded from outgroups. Both MP and ML favor the MP topology when Green-tailed Towhee is included with the other outgroup species. (B) Unrooted topology of the phylogenetic relationships among four fox sparrow groups. Rooting differences between MP and ML are shown by arrows.

DISCUSSION

Our ingroup topology (Fig. 1) conflicts with the previous RFLP (Zink 1994) and *cyt-b* (Zink and Blackwell 1996) studies. However, those previous analyses used relatively few characters. In the present analysis, with a larger data set and multiple outgroups, both maximum parsimony and maximum likelihood found the same relationships among the four groups of *Passerella*. Although the bootstrap values were low, we consider that the best working hypothesis available. The main unresolved issue concerns identification of the proper root (Fig. 1). Using four outgroup taxa (including Green-tailed Towhee) the red group was identified as the sister to all others, whereas if the Green-tailed Towhee is excluded, either the red or thick-billed groups were basal. The likely reason for uncertainty over placement of the root is that the ingroup taxa are almost equidistant from each other, and all are >11% from the nearest outgroup taxon. Distant outgroups are known to yield spurious rooting (Smith 1994).

Typically, one would resolve that latter problem by including more closely related outgroup taxa. However, these taxa, and in particular *S. arborea*, are the closest living relatives to *Passerella* based on extensive mtDNA sequence comparisons (J. Klicka pers. comm.). Thus, although it might preclude definitive rooting, sequence comparisons suggest that *Passerella* has been evolving independently for a considerable period, or that taxa more closely related to it than *S. arborea* have recently become extinct, as suggested by Zink and Slowinski (1995) for other passerines. Thus, genetic similarity of the four groups coupled with the large distance to the nearest outgroup suggests that resolution of the root for *Passerella* will be elusive.

The Fox Sparrow is one of several putative biological species in which the haplotype tree consists of reciprocally monophyletic groups (Zink et al. 2000). Those groups are all allopatric, which suggests a relatively recent origin due to insufficient ecological differences promoting sympatry. The close genetic distance among all four groups suggests that the diversification events were close in time, likely in the mid-Pleistocene (Klicka and Zink 1997).

Of interest to the debate over species concepts in ornithology (Zink and McKittrick 1995) is that the hybrid zone between Slate-colored and Thick-billed fox sparrows is apparently between two nonsister taxa. If one followed the biological species concept, the logical outcome would be to consider the forms connected by a hybrid zone (SC and TB) as conspecific, which would misrepresent their evolutionary history (Zink and Davis 1999; Fig. 1). Thus, it is appropriate to consider the four taxa as phylogenetic and evolutionary species. Predicting biological species status requires field observations on mating tendencies among group (Zink and Kessen 1999).

The topology suggests ways in which the evolution of reproductive isolation should be considered. For example, the two taxa with the highest frequency of hybridization (SC, TB) are similar in plumage color, but differ in bill size. Hence, bill size does not appear to function as an isolating mechanism, although in the hybrid zone, bill sizes tend to be more similar (Zink 1994). Given the apparent importance of song in avian mate choice, the topology of Figure 1 leads one to predict that ancestral features of song are likely retained between those two groups. Other pairwise combinations of taxa in which

hybridization is less frequent differ in plumage coloration which might, in this case, function as an isolating mechanism (and is amenable to testing; Zink 1996). By mapping reproductive compatibility and isolation onto a phylogenetic tree, the character basis of mate choice becomes clearer. That is reversed under the biological species concept where information on mating tendencies is used *a priori* to define species.

The mitochondrial control region is generally thought to evolve at a faster rate than protein coding mitochondrial genes (e.g. Wenink et al. 1993, Tarr 1995, Baker and Marshall 1997). However, in Fox Sparrows CR I has 50% as many variable sites as the three protein coding regions. This same pattern is evident in other passerines (Weckstein et al. 2001, Zink and Blackwell 1998, Questiau et al. 1998). Although CR I might be more variable in comparisons of taxa showing saturation of third positions in coding genes, at low divergences, both coding and noncoding genes in the mtDNA should show similar numbers of variable sites. That perhaps supports the notion that third-position transitions in mitochondrial coding genes are neutral or nearly so.

ACKNOWLEDGMENTS

We thank F. Sheldon, A. Kessen, S. Hackett, J. Rising, and an anonymous reviewer for useful comments on the manuscript. Funding was provided by the Frank M. Chapman Memorial Fund from the American Museum of Natural History, the Dayton and Wilkie Funds at the University of Minnesota, and the National Science Foundation (BSR-8906621).

LITERATURE CITED

- AMERICAN ORNITHOLOGISTS' UNION. 1957. Check-list of North American Birds, 5th ed. Baltimore, Maryland.
- BAKER, A. J., AND H. D. MARSHALL. 1997. Mitochondrial control region sequences as tools for understanding evolution. Pages 51–82 in *Avian Molecular Evolution and Systematics* (D. P. Mindell, Ed.). Academic Press, New York.
- DODGE, A. G., A. J. FRY, R. C. BLACKWELL, AND R. M. ZINK. 1995. Comparison of phylogenies derived from two molecular data sets in the avian genera *Pipilo* and *Spizella*. *Wilson Bulletin* 107: 641–654.
- FARRIS, J. S., M. KÄLLERSJÖ, A. G. KLUGE, AND C. BULT. 1994. Testing significance of congruence. *Cladistics* 10:315–320.

- FARRIS, J. S., M. KÄLLERSJÖ, A. G. KLUGE, AND C. BULT. 1995. Constructing a significance test for incongruence. *Systematic Biology* 44:570–572.
- FELSENSTEIN, J. 1985. Confidence limits on phylogenies: An approach using the bootstrap. *Evolution* 39:783–791.
- HACKETT, S. J. 1996. Molecular phylogenetics and biogeography of tanagers in the genus *Ramphocelus* (Aves). *Molecular Phylogenetics and Evolution* 5:368–382.
- JOHNSON, K. P., AND M. D. SORENSON. 1998. Comparing molecular evolution in two mitochondrial protein coding genes (cytochrome-*b* and ND2) in the dabbling ducks (Tribe: Anatini). *Molecular Phylogenetics and Evolution* 10:82–94.
- KIMURA, M. 1980. A simple method for estimating evolutionary rate of base substitutions through comparative studies of nucleotide sequences. *Journal of Molecular Evolution* 16:111–120.
- KLICKA, J., K. P. JOHNSON, AND S. M. LANYON. 2000. New World nine-primaried oscine relationships: Constructing a mitochondrial DNA framework. *Auk* 117:321–336.
- KLICKA, J., AND R. M. ZINK. 1997. The importance of recent ice ages in speciation: A failed paradigm. *Science* 277:1666–1669.
- KOCHER, T. D., W. K. THOMAS, A. MEYER, S. V. EDWARDS, S. PAABO, F. X. VILLABLANCA, AND A. C. WILSON. 1989. Dynamics of mitochondrial DNA evolution in animals: Amplification and sequencing with conserved primers. *Proceedings of the National Academy of Sciences USA* 86:6196–6200.
- KUMAR, S., K. TAMURA, AND M. NEI. 1993. MEGA: Molecular Evolutionary Genetics Analysis, version 1.02. The Pennsylvania State University, University Park.
- LANSMAN, R. A., R. O. SHADE, J. F. SHAPIRA, AND J. C. AVISE. 1981. The use of restriction endonucleases to measure mitochondrial DNA sequence relatedness in natural populations. III. Techniques and potential applications. *Journal of Molecular Evolution* 17:214–216.
- LINSDALE, J. M. 1928. Variations in the Fox Sparrow (*Passerella iliaca*) with reference to natural history and osteology. University of California Publications in Zoology 30:251–392.
- POSADA, D., AND K. A. CRANDALL. 1998. MODELTEST: Testing the model of DNA substitution. *Bioinformatics* 14:817–818.
- QUESTIAU, S., M.-C. EYBERT, A. R. GAGINSKAYA, L. GIELLY, AND P. TABERLET. 1998. Recent divergence between two morphologically differentiated subspecies of Bluethroat (Aves: Muscicapidae: *Luscinia svecica*) inferred from mitochondrial DNA sequence variation. *Molecular Ecology* 7:239–245.
- SHIMODAIRA, H., AND M. HASEGAWA. 1999. Multiple comparisons of log-likelihoods with applications to phylogenetic inference. *Molecular Biology and Evolution* 16:1114–1116.
- SMITH, A. B. 1994. Rooting molecular trees: Problems and strategies. *Biological Journal of the Linnean Society* 51:279–292.
- SWARTH, H. W. 1920. Revision of the avian genus *Passerella* with special reference to the distribution and migration of the races in California. University of California Publications in Zoology 21:75–224.
- SWOFFORD, D. L. 2000. PAUP*: Phylogenetic Analysis Using Parsimony, version 4.0, beta. Sinauer, Sunderland, Massachusetts.
- TARR, C. L. 1995. Primers for amplification and determination of mitochondrial control-region sequences in oscine passerines. *Molecular Ecology* 4:527–529.
- WECKSTEIN, J. D., R. M. ZINK, R. C. BLACKWELL-RAGO, AND D. A. NELSON. 2001. Anomalous variation in mitochondrial genomes of White-crowned (*Zonotrichia leucophrys*) and Golden-crowned (*Z. atricapilla*) sparrows: Pseudogenes, hybridization, or incomplete lineage sorting? *Auk* 118:231–236.
- WENINK, P. W., A. J. BAKER, AND M. G. J. TILANUS. 1993. Hypervariable-control-region sequences reveal global population structuring in a long-distance migrant shorebird, the Dunlin (*Calidris alpina*). *Proceedings of the National Academy of Sciences USA* 90:94–98.
- ZINK, R. M. 1986. Patterns and evolutionary significance of geographic variation in the Shistacea group of the Fox Sparrow (*Passerella iliaca*). *Ornithological Monographs*, no. 40.
- ZINK, R. M. 1994. The geography of mitochondrial DNA variation, population structure, hybridization, and species limits in the Fox Sparrow (*Passerella iliaca*). *Evolution* 48:96–111.
- ZINK, R. M. 1996. Species concepts, speciation and sexual selection. *Journal of Avian Biology* 27: 1–6.
- ZINK, R. M., G. F. BARROWCLOUGH, J. L. ATWOOD, AND R. C. BLACKWELL-RAGO. 2000. Genetics, taxonomy and conservation of the threatened California Gnatcatcher. *Conservation Biology* 14:1394–1405.
- ZINK, R. M., AND R. C. BLACKWELL. 1996. Patterns of allozyme, mitochondrial DNA, and morphometric variation in four sparrow genera. *Auk* 113:59–67.
- ZINK, R. M., AND R. C. BLACKWELL. 1998. Molecular systematics and biogeography of aridland gnatcatchers (genus *Poliophtila*), and evidence supporting species status of the California Gnatcatcher (*P. californica*). *Molecular Phylogenetics and Evolution* 9:26–32.

- ZINK, R. M., AND J. I. DAVIS. 1999. New perspectives on the nature of species. Pages 1505-1516 in *Proceedings of the 22 International Ornithological Congress* (N. J. Adams, and R. H. Slotow, Eds). BirdLife South Africa, Johannesburg.
- ZINK, R. M., AND A. E. KESSEN. 1999. Species limits in the Fox Sparrow: Past, present and a recipe for resolution. *Birding* 31:508-517.
- ZINK, R. M., AND M. C. MCKITRICK. 1995. The debate about species concepts and its implications for ornithology. *Auk* 112:701-719.
- ZINK, R. M., AND J. SLOWINSKI. 1995. Tempo of avian diversification in the Pleistocene. *Proceedings of the National Academy of Sciences USA* 92: 5832-5835.

Associate Editor: S. Hackett